

## B-1000 Specification Sheet



Instant filtered drinking water.



### **Ambient filtered water**

Enjoy the convenience of having clean, healthy ambient temperature filtered water always on tap, ideal for drinking or cooking.

### **Energy Efficiency**

There is no need to compromise your lifestyle to lessen your carbon footprint. The B-1000 requires no power consumption for operation which ensures negligible running costs.

### **Space Saving.**

The B-1000 offers exceptional space saving at only 130mm wide x 130mm deep, it fits easily within a standard cupboard compartment and allows you to make the most of the available area.

Australian designed, manufactured and owned.



# B-1000 Specification Sheet

## Specification and Guide to model selection

Product Number	Description	Suggested no. of persons	Ambient cups / hour	Unit Height (mm)	Unit Width (mm)	Unit Depth (mm)
911000	B-1000	Family use	Unlimited	320	130	130

### Water Supply

A single 15mm (1/2") stop-tap with a male thread should be installed in an easily accessible position. Water supply must be microbiologically safe to drink, with a minimum dynamic water pressure of 250kPa to a maximum of 1200kPa.

### Options and accessories

**Dispenser Styles:** The B-1000 is supplied with a standard Round Slimline Dispenser. The Square Slimline is an optional style.  
**Billi Font:** Allows the dispenser to be located away from sink areas.  
 Finished in polished Stainless Steel, optional Brushed Chrome, Gloss Black or Matte Black finish available.  
**Dispenser Riser:** 70mm & 120mm dispenser extension - supplied standard with the Billi Font.

### Warranty

The B-1000 range is covered by a comprehensive 2 year warranty on all parts and labour.

### Technical Advice

Contact Merquip Ltd on  
0800 636 0 636

### Filtration

Billi have partnered with globally recognised brand Pentair Everpure to create the most technologically advanced filtration for instant boiling and chilled filtered water systems. It removes sediment and chemicals, allows the flow of minerals through without scale build up and suppresses harmful bacteria in the water. Due to the unique Fibredyne™ technology, our filters have a longer life, higher flow rate and lower pressure drop, leaving you with healthy fresh water. All Billi cartridges are certified by global public safety agency NSF International.

### Certifications

Every Billi drinking water appliance is manufactured under a certified quality control system. The Billi B-1000 model have been tested and comply with all required standards including: Watermark Licence Number 21525; Tested to; AS3498 and AS/NZS4020; Victorian Electrical Safety Act 1998 Approval Number CS100600V, AS/NZS ISO 9002; AS1428 Accessibility Design Requirements; Section J6 of the BCA; Certificate Number QEC 11627; C-Tick approved.

### Preferred Installation Layout

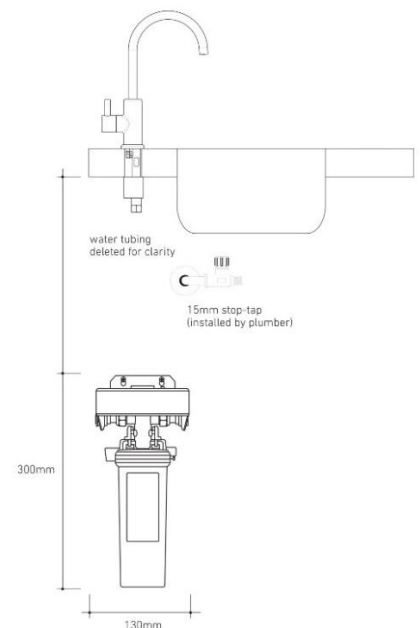

Merquip Ltd  
14 Angle St  
Onehunga  
Auckland 1061

Telephone: 0800 636 0 636  
Email: info@merquip.co.nz  
Website www.merquip.co.nz

Designed and manufactured in Australia

As Billi Pty Ltd has a policy of continual improvement, all details are subject to change without notice.  
All goods sold are subject to our standard terms and conditions.